

Compact Top Load Case Packer KTB-100



- Compact design at only 15 feet long with a max speed of 15 cases/min
- Quick and simple changeover
- Customized robotic loading allowing for a wide range of products
- Built-in case erector and sealer (hotmelt and tape options available)
- Simple maintenance
- A proven robust design

APPLICATIONS



Liquid Detergent



Rice



Canned Items

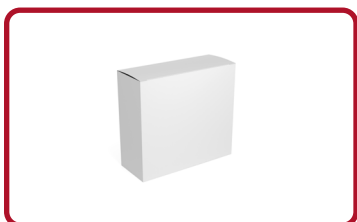

Cartons



Snacks



Confectionary

A ROBUST, COMPACT CASE PACKER

MACHINE DETAILS

ERGONOMIC DESIGN



Not only does the size of the KTB-100 boost efficiency, it is also manufactured to keep your employees comfortable working on it thanks to its ergonomic design.

SIMPLE INTEGRATION



Our KTB-100 is one of the simplest machines on the market when it comes to robotic integration. Whether you're looking for a gantry or delta robot, the KTB-100 can handle it!

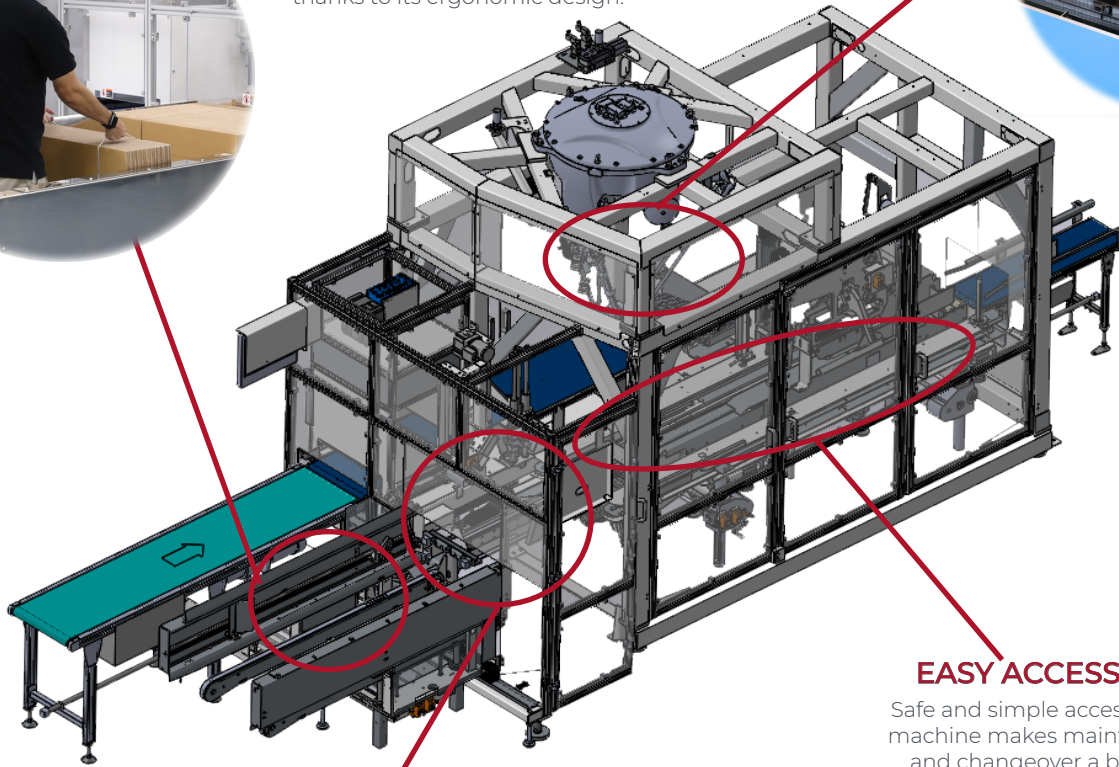

EASY ACCESS

Safe and simple access to the machine makes maintenance and changeover a breeze!

BUILT-IN ERECTOR

The KTB-100 has a built-in case magazine and erector, allowing for more efficiency as well as a smaller footprint.

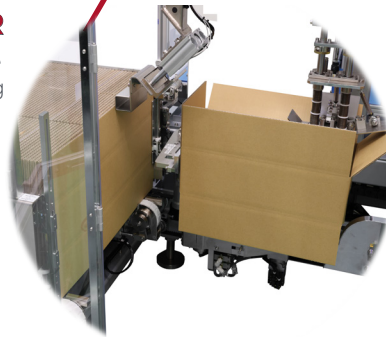

SPECIFICATIONS

L	W	H	Speed
min: 8"	min: 6"	min: 5.125"	15 cases per minute
max: 19.5"	max: 15.5"	max: 13.5"	

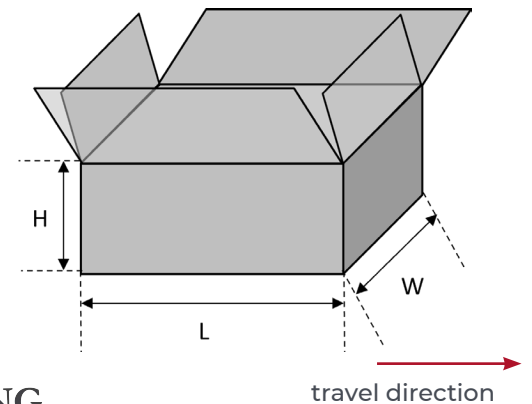

NEWAY  PACKAGING
CORPORATION

(800) 456-3929 | www.newaypkgshop.com | sales@newaypkg.com